

TECH PACK

# MUSIC IS BETTER LIVE. *AT THE CLYDE*



[ClydeTheatre.com](http://ClydeTheatre.com)

1808 Bluffton Road, Fort Wayne, IN 46809

06/03/2022



# WELCOME TO THE CLYDE

In this tech pack, we hope to provide all the information needed for you to have an enjoyable and stress-free day here at The Clyde.

The venue was designed with the artist in mind, making it easy for your production to enter our building and put on a successful show for your fans.

Since reopening in 2018 following a \$9 million renovation, this art deco masterpiece has been transformed into a premier entertainment venue that has played host to some of the world's top touring talent.

## FEATURES OF THE CLYDE INCLUDE:

- 21,000-square-foot main performance hall
- 7,000-square-foot dressing rooms & hospitality lounge
- Industry-standard sound and lighting systems
- On-site restaurant and coffee shop available for catering, hospitality, and select VIP experiences

## CONTACTS

**EXECUTIVE DIRECTOR**  
**Gregg Coyle**  
 1 (260) 747-0989 x8591  
 gregg@clydetheatre.com

**PRODUCTION MANAGER**  
**Drew Consalvo**  
 1 (260) 747-0989 x1809  
 1 (818) 749-4609  
 drew@clydetheatre.com

**BOX OFFICE MANAGER**  
**Sara Trombly**  
 1 (260) 747-0989 x8576  
 sara@clydetheatre.com

**MARKETING**  
 marketing@clydetheatre.com

## IMPORTANT INFORMATION

**BOX OFFICE / SHIPPING / VENUE ADDRESS**  
**The Clyde Theatre**  
 1808 Bluffton Road, Fort Wayne, IN 46809  
 1 (260) 747-0989

**PLEASE NOTE BOX OFFICE HOURS FOR SHIPMENTS**  
 12PM–6PM Monday to Thursday  
 10AM–6PM Friday  
 2 hours prior to doors on weekends

**LOADING DOCK / VAN & TRAILER / BUS PARKING**  
 Loading docks and the production lot are accessed from the rear of the building. *(See map on page 3)*

**GPS COORDINATES**  
 41.0522° N, 85.1614° W

## PARKING INFORMATION

The Clyde is located at 1808 Bluffton Road, Fort Wayne, IN 46809 between Broadway and Brooklyn Avenue. We have ample parking for four buses with shore power. Two semi trucks can park at our loading dock, with additional box truck parking available.

**There is no truck or bus access from Broadway or Fairfield coming from the north due to low bridge clearance.**

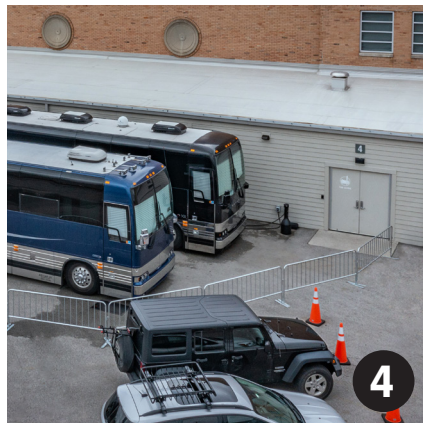

## TECHNICAL DETAILS

<b>LOAD IN</b>	Access from two truck docks at stage level — 20' push to stage. Buses with trailers unload on the east side of the loading dock (see map on page 3), up the ramp. Lower-than-dock-height platform available for box truck unloading.
<b>STAGE ACCESS</b>	Accessible from loading docks, ramp, and artist doors. Access to the stage from overhead doors stage left and stage right. They are closed for performances.
<b>LOADING DOOR DIMENSIONS</b>	13'10" high x 8' wide
<b>STAGE DOOR DIMENSIONS</b>	13'10" high x 8' wide
<b>STAGE WIDTH</b>	70' downstage   38' between drapes   38' upstage
<b>STAGE DEPTH</b>	32.5'
<b>STAGE HEIGHT</b>	4'
<b>STAGE TYPE</b>	Concrete
<b>TRIM HEIGHT</b>	27' to truss
<b>GRID HEIGHT</b>	31.5' from floor to steel beams
<b>RISERS</b>	Risers available for rent per advance no later than two weeks before event date.
<b>DEAD CASE STORAGE</b>	Ample dead case storage on loading dock.
<b>DISTANCE TO FOH</b>	70'
<b>CABLE RUN TO FOH</b>	100' — all cable will run through 12" cable conduit from stage to FOH. Floor-access vault doors are located center of house at downstage lip and FOH location.
<b>BACKLINE</b>	There is no backline in-house.
<b>LABOR</b>	Our house crew will act as loaders, stagehands, and technicians upon request. Please advance all labor needs at least two weeks before event date.
<b>RIGGING</b>	All rigging must be approved by production manager in advance of event load in. Riggers are provided per advance. Rigging details available per advance. Details on page 11 and 12.
<b>FORKLIFT</b>	There is no forklift available on-site. A stacking motor is available by advance.
<b>CONFETTI</b>	Biodegradable confetti is permitted. Mylar and metal confetti are not permitted. There is a \$500 cleanup charge for all confetti.
<b>CRYO</b>	Please give production manager five days' notice if you require CO <sub>2</sub> .
<b>PYRO</b>	Pyro and open flame are permitted at The Clyde but must be advanced and require prior written approval by general manager. A permit from the City of Fort Wayne Fire Department is required. The permit process may take some time, so please contact production manager as soon as possible.
<b>HAZE</b>	Production manager must be notified before any haze can be used in the building, including in rehearsals and soundcheck.
<b>SOFT GOODS</b>	House blacks on upstage and wings. Any artist draperies, banners, and backdrops must have active fire certificate.
<b>SPOTLIGHTS</b>	There are no spotlights in-house. Spotlights can be rented by venue upon request at artist cost.

## GUEST / HOUSE / STAGE POWER

RATING	LOCATION	TERMINATION	USER
<b>Lighting</b> 400 amps / 3-phase 120/208V	Upstage right Pass-through on lighting distro	Camlock	House lights, touring lights, video
<b>Sound</b> 200 amps / 3-phase 120/208V	Downstage left	Camlock	Touring audio

## AUDIO SPECIFICATIONS

### LEFT/RIGHT MAIN PA

20 x JBL VTX A12 Dual 12" Line Array Loudspeaker

### SUBS

8 x JBL VTX G28 Dual 18" Subwoofer under stage

### FRONT FILL

7 x JBL VT4886 Subcompact Passive 3-way Line Array

### DELAY

5 x JBL VRX932LA 12" Bi-amplified 2-way Line Array

### AMPS

14 x Crown I-Tech 4x3500HD 4-channel, 4000W @ 4Ω

4 x Crown I-Tech 12000HD 2-channel, 4500W @ 4Ω

1 x BSS Soundweb London BLU-160

### STAGE MONITORING

12 x JBL VTX M22 Dual 12" Stage Monitor  
*(8 more available by request) on 8 mixes*

2 x JBL VTX F35/95 Dual 15" 3-way Loudspeaker

1 x JBL VTX F18S 18" Compact Single Subwoofer

### AUDIO CONSOLES

Avid VENUE S6L-32D-192, 2 x FOH/Monitors

Avid VENUE Stage 64 — 64 analog in / 24 analog out / 8 digital out

### WIRELESS MICS AND IN-EARS

4 x Shure Axient AD4DUS

8 x Shure Axient AD2 w/ 4 x SM58, 4 x KSM8, 2 x Telefunken M81-WH

4 x Shure P10T G10

8 x Shure P10R G10

### MICROPHONES

#### SHURE

12 x SM57, 2 x Beta 57A, 10 x SM58, 2 x Beta 58A, 2 x Beta 181,  
 2 x Beta 87A, 4 x KSM141, 4 x KSM137, 6 x Beta 98AMP, 4 x KSM32,  
 2 x KSM 44A, 2 x Beta 52A, 2 x Beta 91A, 1 x Beta 98H, 6x Beta 56A,  
 1x Twinplex TH53, 2x SM81, 1x KSM313

#### TELEFUNKEN

2 x M81-WH, 4 x M80, 4 x M81, 8 x M81-SH, 4 x M80-SH,  
 6 x M60 FET, 2 x M82

#### SENNHEISER

4 x MD 421, 2 x e 906, 4 x e 945

#### AUDIO-TECHNICA

3 x ATM 230

1 x ATM 250

2 x ATM 450

1 x ATM 650

2 x ATM 2021

#### COUNTRYMAN

4 x E6

#### RADIAL

4 x JDI, 4 x J48, 4 x JDI Stereo

#### WHIRLWIND

3 x PC DI

Full complement of K&M microphone stands

## LIGHTING SPECIFICATIONS

### EUROTRUSS

2 x Pre-rig 40' Trussing  
10x10 40' Box

### STAGEMAKER

13x Half-Ton Chain Hoists

### MOTION LABS

Lighting Distro w/ Cam Throughs

### CHAMSYS

MQ500 Stadium Console

### CHAUVET

4x Rogue R3 Spots  
6x Rogue R3X Wash

### CLEAR-COM

2-channel Wired Coms at SL, SR, FOH, and spot positions

### MARTIN

8 x MAC Quantum Profile  
2 x MAC Encore Performance WRM  
8 x MAC Quantum Wash  
4 x Atomic 3000 LED  
24 x Rush PAR 2

### IN-HOUSE VIDEO PROJECTION

Digital Projection Highlite Laser II 13k Projector  
Decimator MD Cross V2  
Da-Lite 13.3' H x 23.67' W Motorized Screen—upstage center  
Roland V-1HD 4-CH Video Switcher

*See lighting patch and plot on pages 11 and 12.*

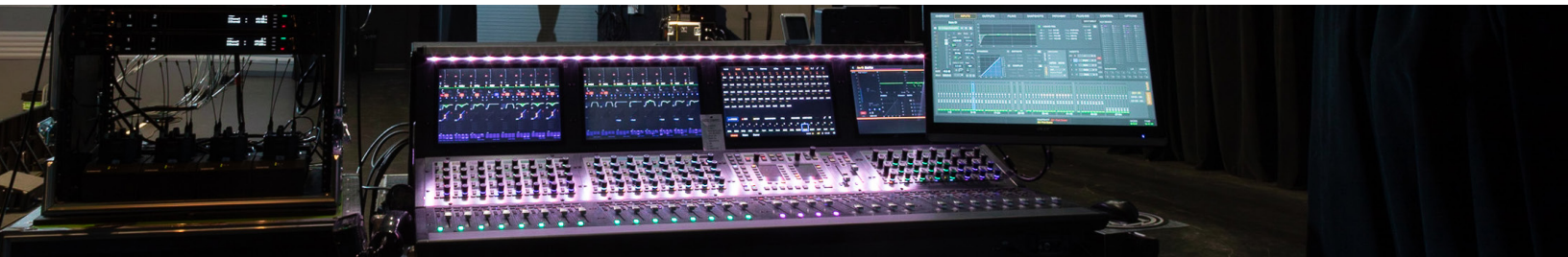

## SECURITY / CREDENTIALS / MEET & GREET / SETTLEMENT / CAMERA POLICY

### SECURITY

To provide the safest and most comfortable experience for our artists and patrons, all working personnel, guests, and artists will be expected to pass through a metal detector before entering the building. Please understand that our only concern is preventing weapons from entering the building, and your privacy is of the utmost importance to us. Our backstage is your home, and we encourage you to go about your business as you would anywhere else. Please let the production manager know if you have any questions regarding the metal detector or any security procedures at The Clyde.

### SECURITY MEETING

A security meeting with the executive director, production manager, and a tour representative will take place one hour prior to doors.

### CREDENTIALS

The Clyde will honor touring credentials and can provide house passes upon request.

### GUEST LIST

All guest list names must be turned in to the production manager or other backstage venue representative no later than 30 minutes prior to doors opening.

### VIP or MEET & GREET

All VIP, meet & greet, and early entrants must be advanced with the production manager two weeks prior to show. There is a \$200 fee for any VIP, meet & greet, or early-entry programs that require security/venue staff.

### PHOTO POLICY

All SLR or DSLR cameras with detachable lenses in the venue must have a photo pass and prior written consent of artist management. We will honor all touring policies. We can provide photo passes upon request.

### VIDEO POLICY

Any film crew or video shoot details must be advanced prior to the show. A release must be signed for any video recording.

### BARRICADE

We have Mojo-style barricades in-house for front-of-stage and FOH areas.

### SETTLEMENT

All cash requests must be made two weeks in advance. No cash is on hand unless otherwise advanced.

### SMOKING

There is a strict no-smoking policy at The Clyde Theatre. Smoking is allowed only in designated areas outside the building.

## CATERING / HOSPITALITY / MERCHANDISE / RUNNERS

<b>CATERING</b>	The Clyde provides catering through our on-site restaurant, The Club Room. We can also work with a number of preferred local vendors to fulfill catering needs with advance notice. Catering is set up in the greenroom located next to dressing room #4.
<b>HOSPITALITY</b>	All hospitality needs are to be advanced with production manager/hospitality coordinator and are per budget, unless otherwise noted. Please submit all hospitality riders two weeks prior to your show during production advance.
<b>LIQUOR</b>	In accordance with the Indiana Alcohol & Tobacco Commission, all liquor (including backstage liquor) must be purchased in-house from The Clyde Theatre. All liquor orders should be placed at least one week in advance.
<b>DRESSING ROOMS</b>	We have four private dressing rooms and one greenroom area located backstage on the first floor. Dressing room curfew is two hours after the show ends.
<b>DIMENSIONS</b>	Dressing Room #1 — 14' x 20', Dressing Room #2 — 22' x 20', Dressing Room #3 — 20' x 22', Dressing Room #4 — 14' x 20', Greenroom — 14' x 20'
<b>DRESSING ROOM ACCESS</b>	Dressing rooms are accessed backstage from entrance in bus lot.
<b>SHOWERS</b>	Dressing rooms #2 and #3 have showers.
<b>LAUNDRY</b>	We have a clothes washer and dryer located in the utility closet backstage.
<b>WI-FI</b>	Private production Wi-Fi is provided. Password is located on the wall in each dressing room and in greenroom.
<b>CATERING / CREW</b>	Hospitality lounge and catering room is located backstage next to dressing room #4.
<b>RUNNERS</b>	All runners are per advance and in personal vehicles. Any vehicle rentals will be at artist cost.
<b>RESTAURANTS</b>	We have an on-site restaurant and coffee shop, The Club Room and Crescendo Coffee & More, available. There are also several dining options in the surrounding area. Local menu books are provided in each hospitality lounge.
<b>MASSAGE THERAPISTS</b>	Please let us know if you are in need of a massage therapist, and we can arrange for one day of show.
<b>EMT / MEDICAL / POLICE</b>	We will have one EMT on staff unless otherwise noted. Police are on-site at every show.
<b>MERCHANDISE</b>	The house cut is per contract. Our house seller is \$100 flat rate. Please advance with the production manager if you are in need of a seller. Our in-house merchandise representative will count in/out for each show. Please let us know if you have a specific time that you'd like to count in. Please advance any cash needs at least two weeks in advance.

# Sweetwater®

Music Instruments & Pro Audio

Visit our partners at Sweetwater while you're in town,  
located just seven miles from The Clyde Theatre.

5501 US Hwy 30 W, Fort Wayne, IN 46818 | (800) 222-4700

## CLYDE THEATRE FLOOR PLAN

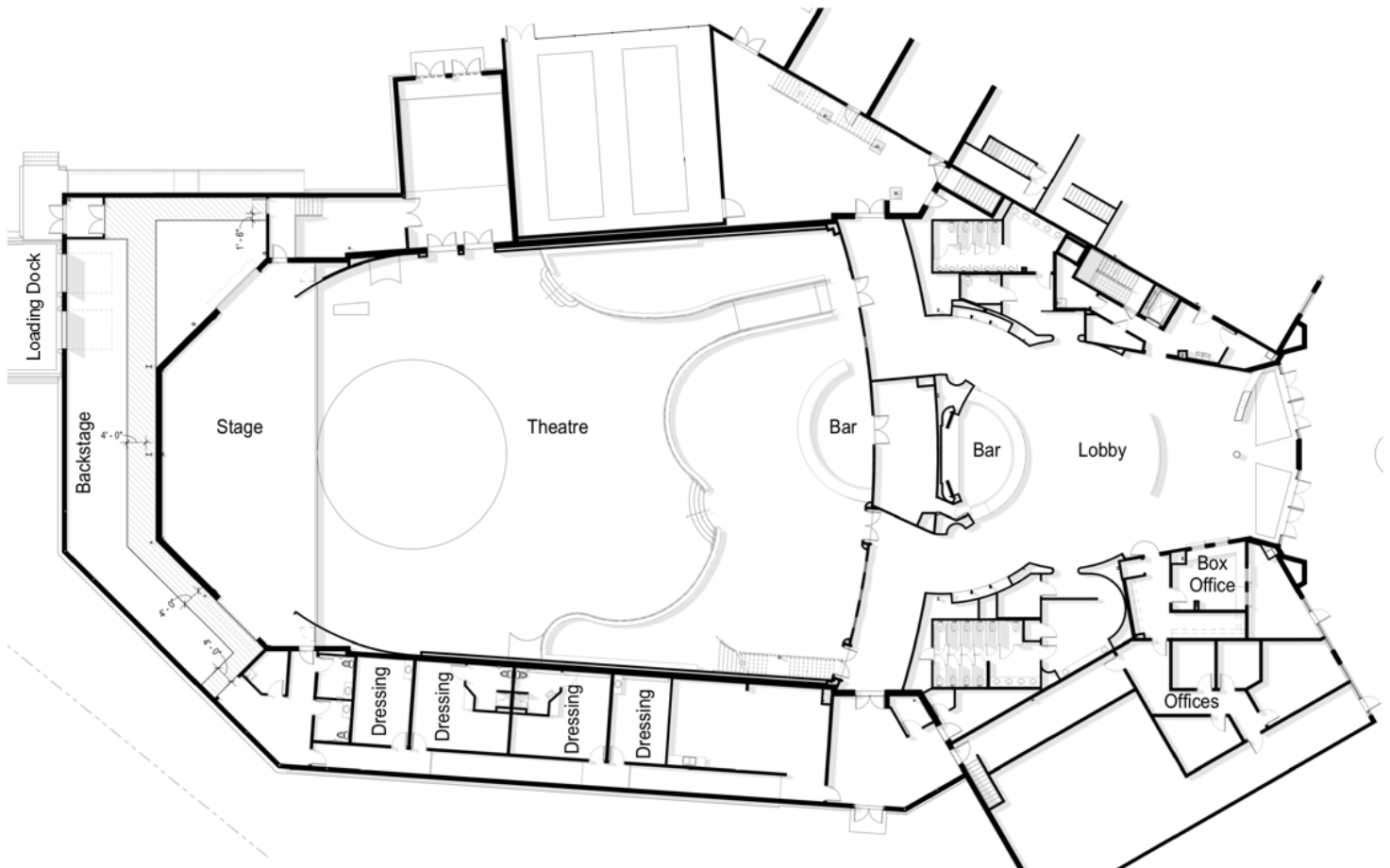

## HOTEL RECOMMENDATIONS

### WYNDHAM GARDEN HOTEL

Ricky Jamison — Director of Sales  
 5750 Challenger Parkway, Fort Wayne, IN 46818  
 (260) 999-6040 | rjamison@wyndhamgardenfw.com

### HILTON FORT WAYNE AT THE GRAND WAYNE CONVENTION CENTER

Dyanne Hower — Sales Manager  
 1020 S. Calhoun Street, Fort Wayne, IN 46802  
 (260) 422-4002 | dhower@hiltonfortwayne.com

### COURTYARD MARRIOTT DOWNTOWN FORT WAYNE

Shelby Peeling — Sales Manager  
 1150 South Harrison Street, Fort Wayne, IN 46802  
 (260) 579-9214 | shelby.peeling@whitelodging.com

### HOLIDAY INN EXPRESS & SUITES

Nate Taylor - Director of Sales  
 5915 Ellison Road, Fort Wayne, IN 46804  
 (260) 408-6611 | nate.taylor@hieftwayne.com



## CLYDE THEATRE LIGHTING PATCH

HEAD NO.	DMX	POSITION	MANUFACTURER	MODEL	MODE
101	1-001	Upstage Truss	Martin	MACQuantumProfile	Basic
102	1-020	Upstage Truss	Martin	MACQuantumProfile	Basic
103	1-039	Upstage Truss	Martin	MACQuantumProfile	Basic
104	1-058	Upstage Truss	Martin	MACQuantumProfile	Basic
105	1-077	Midstage Truss	Martin	MACQuantumProfile	Basic
106	1-096	Midstage Truss	Martin	MACQuantumProfile	Basic
107	1-115	Midstage Truss	Martin	MACQuantumProfile	Basic
108	1-134	Midstage Truss	Martin	MACQuantumProfile	Basic
201	1-153	Upstage Truss	Martin	MACQuantumWash	Basic
202	1-170	Upstage Truss	Martin	MACQuantumWash	Basic
203	1-187	Upstage Truss	Martin	MACQuantumWash	Basic
204	1-204	Upstage Truss	Martin	MACQuantumWash	Basic
205	1-221	Midstage Truss	Martin	MACQuantumWash	Basic
206	1-238	Midstage Truss	Martin	MACQuantumWash	Basic
207	1-255	Midstage Truss	Martin	MACQuantumWash	Basic
208	1-272	Midstage Truss	Martin	MACQuantumWash	Basic
301	1-289	Upstage Truss	Martin	RushPar2Zoom	9CH
302	1-298	Upstage Truss	Martin	RushPar2Zoom	9CH
303	1-307	Upstage Truss	Martin	RushPar2Zoom	9CH
304	1-316	Upstage Truss	Martin	RushPar2Zoom	9CH
305	1-325	Upstage Truss	Martin	RushPar2Zoom	9CH
306	1-334	Upstage Truss	Martin	RushPar2Zoom	9CH
307	1-343	Upstage Truss	Martin	RushPar2Zoom	9CH
308	1-352	Upstage Truss	Martin	RushPar2Zoom	9CH
309	1-361	Upstage Truss	Martin	RushPar2Zoom	9CH
310	1-370	Upstage Truss	Martin	RushPar2Zoom	9CH
311	1-379	Upstage Truss	Martin	RushPar2Zoom	9CH
312	1-388	Upstage Truss	Martin	RushPar2Zoom	9CH
313	1-397	Midstage Truss	Martin	RushPar2Zoom	9CH
314	1-406	Midstage Truss	Martin	RushPar2Zoom	9CH
315	1-415	Midstage Truss	Martin	RushPar2Zoom	9CH
316	1-424	Midstage Truss	Martin	RushPar2Zoom	9CH
317	1-433	Midstage Truss	Martin	RushPar2Zoom	9CH
318	1-442	Midstage Truss	Martin	RushPar2Zoom	9CH
319	1-451	Midstage Truss	Martin	RushPar2Zoom	9CH
320	1-460	Midstage Truss	Martin	RushPar2Zoom	9CH
321	1-469	Midstage Truss	Martin	RushPar2Zoom	9CH
322	1-478	Midstage Truss	Martin	RushPar2Zoom	9CH
323	1-487	Midstage Truss	Martin	RushPar2Zoom	9CH
324	1-496	Midstage Truss	Martin	RushPar2Zoom	9CH
401	2-001	Midstage Truss	Martin	AtomicLED3000	14CH
402	2-015	Midstage Truss	Martin	AtomicLED3000	14CH
403	2-029	Midstage Truss	Martin	AtomicLED3000	14CH
404	2-043	Midstage Truss	Martin	AtomicLED3000	14CH
501	2-057	FOH Truss	Martin	MacEncorePerf	38CH
502	2-095	FOH Truss	Martin	MacEncorePerf	38CH
601	2-133	FOH Truss	Chauvet	RogueR3XWash	21CH
602	2-154	FOH Truss	Chauvet	RogueR3XWash	21CH
603	2-175	FOH Truss	Chauvet	RogueR3XWash	21CH
604	2-196	FOH Truss	Chauvet	RogueR3XWash	21CH
605	2-217	FOH Truss	Chauvet	RogueR3XWash	21CH
606	2-238	FOH Truss	Chauvet	RogueR3XWash	21CH
701	2-259	FOH Truss	Chauvet	OvationE260WWIP	2CH
702	2-261	FOH Truss	Chauvet	OvationE260WWIP	2CH
801	2-263	Floor	Chauvet	RogueR3Spot	25CH
802	2-288	Floor	Chauvet	RogueR3Spot	25CH
803	2-313	Floor	Chauvet	RogueR3Spot	25CH
804	2-338	Floor	Chauvet	RogueR3Spot	25CH
901	2-363	Floor	Chauvet	Amhaze Stadium	2CH
902	2-365	Floor	Chauvet	Amhaze Stadium	2CH

# CLYDE THEATRE LIGHTING PLOT

## US Truss

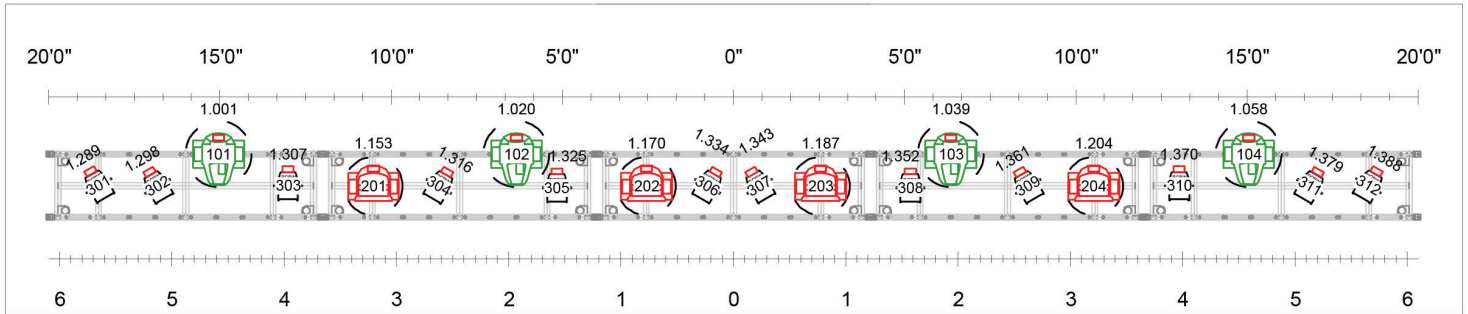

## MS Truss

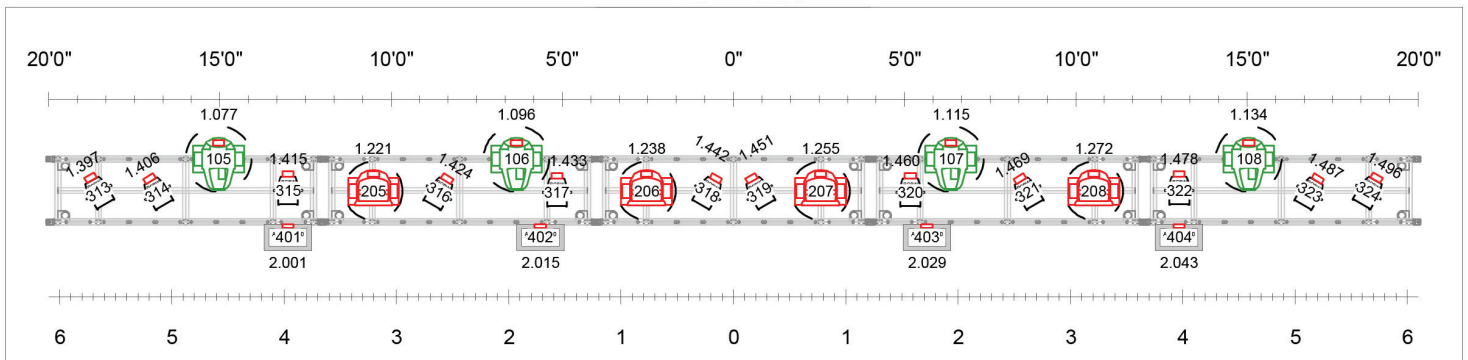

## FOH Truss

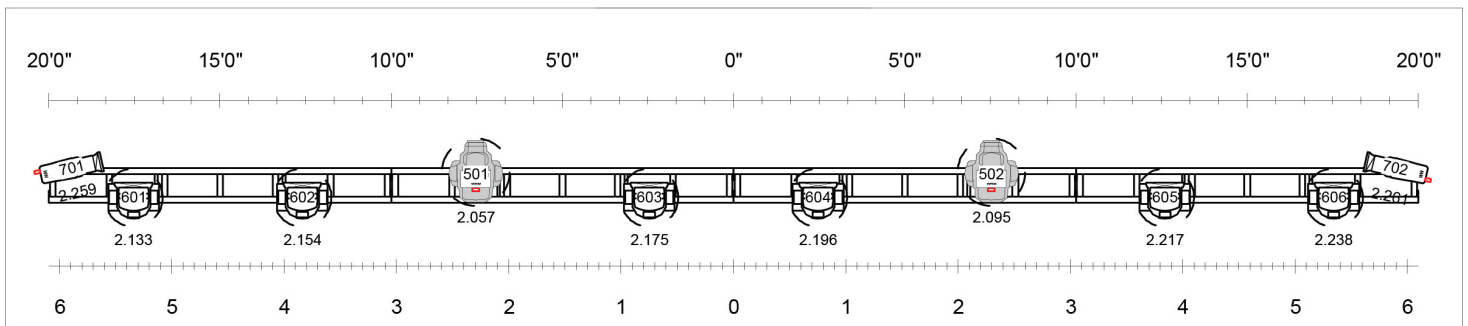

### LEGEND



MAC Encore Performance WRM  
 Martin Mac Quantum Profile  
 Martin Mac Quantum Wash



Martin RUSH PAR 2 RGBW Zoom  
 Atomic 3000 LED  
 Chauvet Rogue R3X Wash

ROOF PLAN — PLATFORM RIGGING

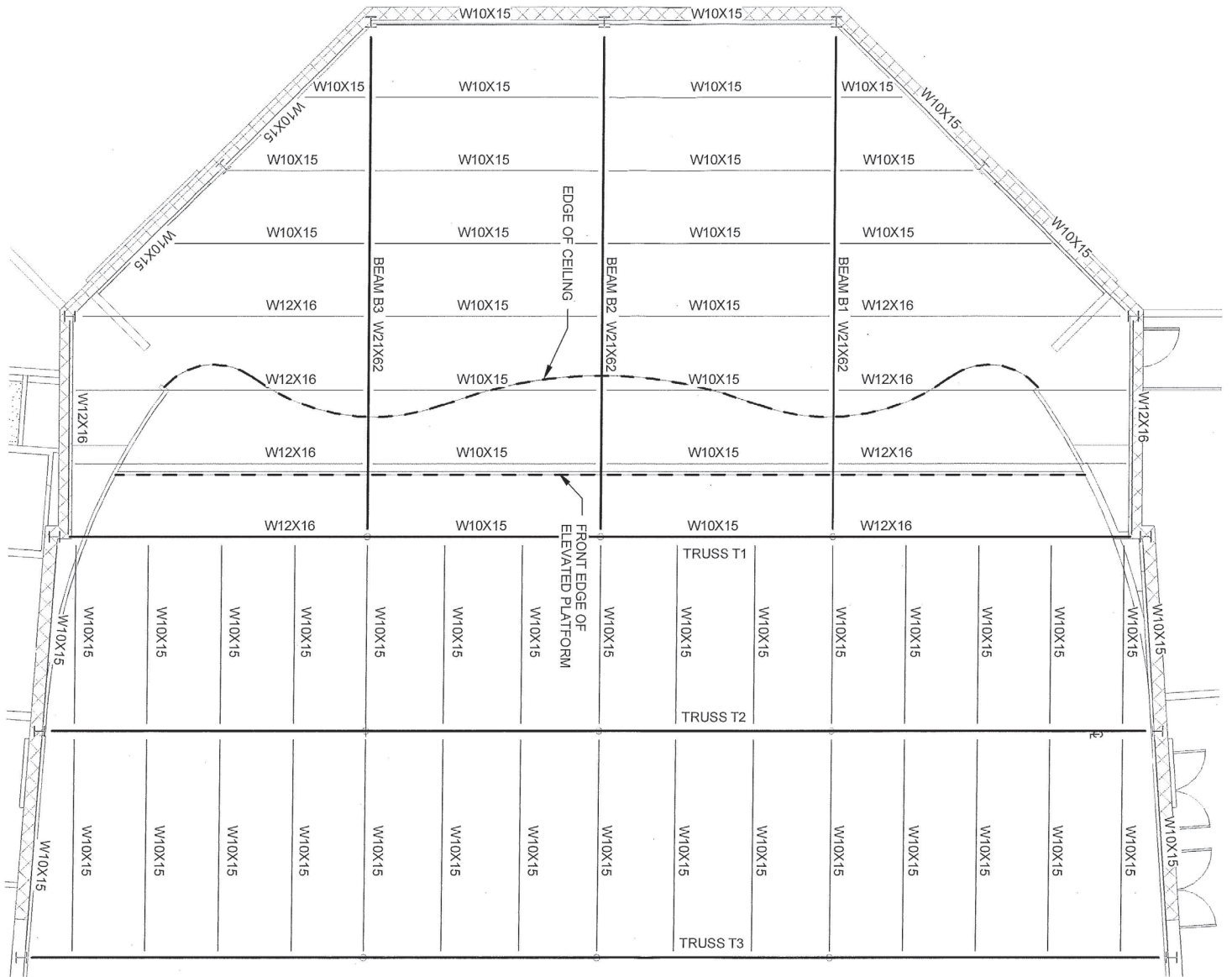

# CLYDE THEATRE RIGGING DETAILS

## MAXIMUM ALLOWABLE RIGGING HOIST LOADS

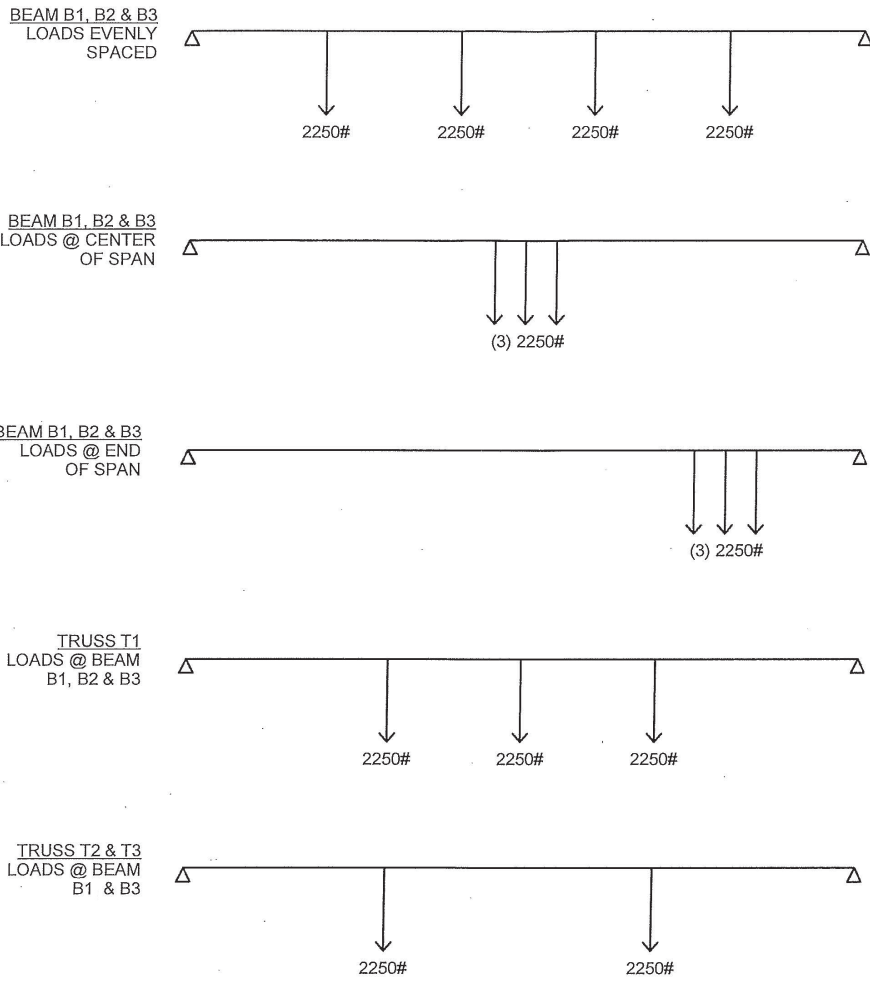

The  
**Clyde**  
Theatre  
Powered by [Sweetwater](#)

[ClydeTheatre.com](#)  
1808 Bluffton Road, Fort Wayne, IN 46809

